

Ghibli R60

20-60 kg / 44-132 lb.
Commercial Coffee Roaster



The **Ghibli R60** commercial coffee roaster was designed to provide the latest technology for those who **appreciate quality**

The Ghibli R60 is not another average commercial drum roaster. Our loyalty to the endless pursuit of excellence ensures that our roaster produces a boutique quality coffee with a full aromatic spectrum in commercial quantities, something hitherto unachieved by standard commercial configurations.

Precision Design

With the help of advanced design software, every attribute of the Ghibli R60's construction was meticulously designed to optimize each part of the roasting process. Thanks to extensive research and painstaking attention to detail, the Ghibli R60 can offer:

- Advanced thermodynamic characterization.
- Precision drum housing, ensuring the drum always spins "in line", with a sturdy design that will bear the load for many years.

- Exact proportion in drum design, achieving an optimal ratio of conductive and convective heat.

- In-drum fluidizing paddles designed to perfectly stir the beans, create greater heat conduction between metal and beans, separate chaff and immediately evacuate the beans from the drum into the cooling group.

Perfect Heat Dispersion

We have conducted intensive research on closed ceramic combustion chambers. The ceramic surrounding the Ghibli R60's drum ensures that the distribution of heat is equal at all times; with cold air unable to penetrate the drum. This presents a marked improvement over the common setup of self-aspirated burners, where heat is applied directly to the drum at a single point.

Clean, Safe and Efficient Heating System

Coffee-Tech's entire Ghibli line features a highly efficient turbo gas burner.

This special roaster is equipped with a dual-stage modulated burner; providing a wide range of settings able to maintain a constant heat. This clean heat source provides maximum gas burning efficiency with minimum levels of carbon monoxide emission. Safe, economical and stable, it features many parameters for control and calibration, all described in detail in our user manual.

Comprehensive Set of Features

At Coffee-Tech Engineering, we pay special attention to the less obvious details, such as the compact, efficient structure of the roaster, batch cooling time, drum evacuation time, the size of the monitoring control lens and drum-gate, the addition of a lens in the green bean hopper and more. At the end of the cycle, the entire roasted batch is transferred to the cooling group in a matter of seconds. These features are often ignored but their impact is tangible in the finished brew. At Coffee-Tech Engineering, every setting and modification is tested in our laboratory to ensure we provide the best cup of coffee possible.

[Optional] Roasting Software

Alongside the Ghibli R60, we offer unique roasting software, PC operated, developed exclusively by Coffee-Tech Engineering, that completely automates the roasting process. The software enables the user to predefine and program personal roast profiles. By recording the desired heating curves, an endless number of roast profiles can be applied time and again with pinpoint accuracy.

The software analyzes the internal temperature at three distinct points, simultaneously managing the two-stage modulating burner. In addition, the software also controls the drum speed and airflow within the drum, allowing for complete control over the entire process.

Pneumatic Elevator for Green Beans:

This machine is equipped with a floor mounted green bean elevator for easy loading. It can be controlled by the roasting software or manually from the control panel.

Pneumatic doors actuation:

All doors on the Ghibli R60 feature pneumatic actuation, aided by air pistons and electro-valves and can be operated semi-automatically from the control panel or automatically by the software.

Control Panel

The Ghibli R60 is equipped with a self-standing control panel, ergonomically designed for operation and easy maintenance.

The control panel features an emergency stop switch, indicating lamps for the burner and afterburner, a USB port for computer connection, individual switches for all electric and pneumatic functions of the machine, includes optional features such as De-stoner with its individual frequency inverter, and with all other optional features mentioned.

All electrical control components and motor protections are installed in this unit. This allows for very easy maintenance and service without the need to open the machine itself. In the event of a failure, the control board can be shipped separately for repair or exchange.

Cyclone Chaff Collector

This machine comes with a heavy gauge, galvanized, painted steel chaff collector that can be taken apart with basic tools for cleaning. Cleaning is a tedious but necessary procedure on any commercial roaster, but we make it safe and easy to do.

Cooling Group

The Ghibli line is equipped with a stainless steel cooling group, a big screen mesh that requires no cleaning, Teflon agitation blades, and a dedicated high capacity cooling blower. The Cooling Group also features a big cleaning door and pneumatic evacuation opening - all covered for food safety and protection. The cooling cover is designed with two vortex ducts to direct the air in a controlled manner, rather than allowing it to flow randomly and inefficiently.

A New Generation of Roasting Drums

An extensive research and development process has resulted in four distinctive tailor-made drum models for the Ghibli line, each excelling at producing coffee suited to different tastes:

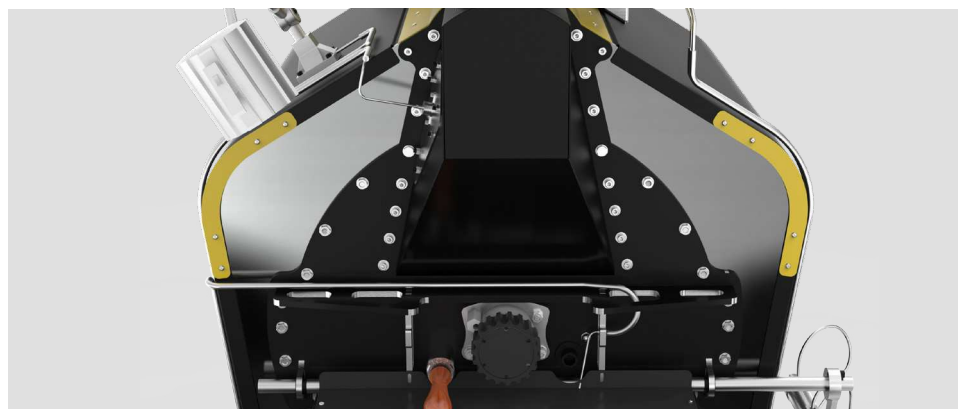

The Next- Gen Vortex TO4 Roasting Drum

In Ghibli R60, airstream blasts in spiral motion into the drum and through the coffee beans, requiring smaller amount of air to enter the roaster for a full effect.

The longer spiral path across the drum and through the coffee bed is unlike the olden traditional roaster mechanisms, which had a perforated back plate allowing huge amounts of air into the drum in a short, straight path.

With our roaster, the beans are not stripped away from their coffee goodness, while the energy is also used to maintain the heat right next to the exhaust without working on the coffee itself. This innovative approach ensures a unique added-value offering for cost-effectiveness, energy optimization, and enhanced flavor.

Lab tests have already shown a huge improvement in the coffee's solids content and density, with amazing improvements in gas consumption, roasting time, fume emission.

The Perfect Roasting System

Achieving a high level of conductive heat has proved the best method for producing a rich cup, and this is where we differ from other manufactures. Since conduction is complicated and presents several unresolved issues, many have abandoned it in favour of convective heat. At Coffee-Tech Engineering we have chosen to invest in extensive research in order to solve these issues.

In doing so, we are proud to offer a machine that truly reflects our beliefs and understanding of coffee roasting.

The Ghibli R60 is equipped with individual frequency inverters for controlling motor speed in all important functions such as the drum rotation, the drum's airflow blower and the de-stoner.

These features aid in achieving better results in any given condition, including various roasting styles and variations in different beans.

The Ghibli R60 roasts continuously, while cooling takes place outside the drum, making it possible to roast up to 135 kg of beans per hour. The Ghibli R60 is user-friendly, ergonomic, quiet and safe. Each

function has an individual motor and heat protection.

We take pride in the Ghibli R60 construction and high-end craftsmanship. This is a result of 3D CAD design, and the use of high quality materials, components and precise manufacturing tools assembled and completed by Coffee-Tech Engineering's passionate artisans.

Our software simulates a long list of tests prior to production; ranging from stress tests, heat dispersion and load distribution.

The Ghibli R60 is available with various heating methods, from natural gas and LPG, to traditional wood and charcoal heating, according to the customer's preference. Being a high-end roaster, the Ghibli R60 will ensure reliable operation together with consistently superb results for many years.



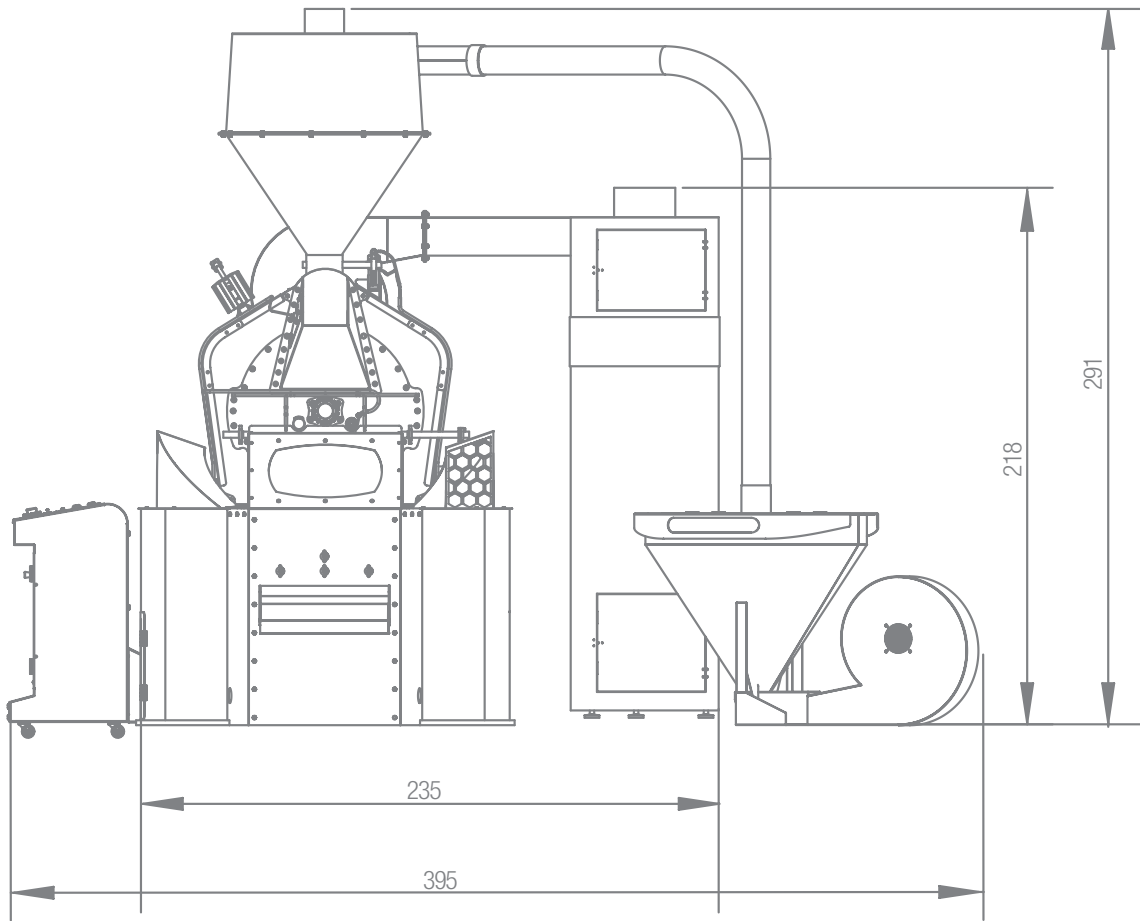

Heating Technology



Conduction



Convection



Indirect Flame
(OPT)

Safety



In Drum
Extinguish



Safety
Manual Crank



Pollution Free
Ambient

Roasting Method



Drum Roasting

Control Features



RDL



Drum Speed
Control



Blower Speed
Control



Multipoint
Temp.



Touch
Screen

Built-in Features



Vortex TO4



Full Modulation
(OPT)



Ceramic
Chamber



Sub-Atmospheric
Combustion Chamber

Sustainability



Low Energy
Consumption



Low NOx

Technical Specifications

Batch Capacity:

20-60 kg / (44-132 lb) of green coffee

Roasting Cycle:

17 minutes \pm 3 batches per hour

Quality and safety compliance:

CE, RoHS, EMC

Electrical Specifications:

50/60 Hz. 7500W 3 Phases
230/380V

Heating Method:

Gas: L.P.G. /Natural Gas (15.5-50 Mcal/h) two individual burners

Drum housing:

Sub atmospheric combustion chamber

Chaff Evacuation:

Cyclone type chaff collector chaff compacting device is optional

Drum Operation:

Direct drive individual heavy-duty gear motor 1.5 hp with frequency inverter for speed control

Cooling Agitation:

Direct drive individual heavy-duty gear motor 1.5 hp.

Cooling Blower:

High capacity 3 hp cooling blower, cooling time 3-4 minutes. Volumax compressed air injection into cooling pan

Drum Venting:

High heat individual blower, 1 hp with frequency inverter for speed control

Safety:

Safety drum discharger
In-drum extinguish

Bearings:

Two (F&R) hi precision slide bearings for cantering and two (F&R) high temperature self-aligned bearings with greasing. Front wet bearing used for drum aligning with fine thread and special wrench. Machine is provided with suitable greasing pump and one kg of high temperature grease. Micrometric drum alignment mechanism

Doors Opening:

All machine's door openings are actuated by pneumatic pistons and controlled by software, or manually from the control board

Body:

Full precision metal work, top quality materials and hardware, galvanized steel, carbon steel and stainless steel. Drum housing front plate SS shielded lifetime good visibility

Also Available:

Traditional wood/charcoal heating conversion / Automatic software

General Dimensions:

237(w) X 275(d) X 281(h) cm
93(w) X 108(d) X 111 (h) inch

Weight:

900kg (1984 lb)